



Extreme®

Connect Beyond the Network

# AP-7522E Access Point

*Installation Guide*

Copyright © 2017 Extreme Networks, Inc. All Rights Reserved.

## Legal Notices

Extreme Networks, Inc. reserves the right to make changes in specifications and other information contained in this document and its website without prior notice. The reader should in all cases consult representatives of Extreme Networks to determine whether any such changes have been made.

The hardware, firmware, software or any specifications described or referred to in this document are subject to change without notice.

## Trademarks

Extreme Networks and the Extreme Networks logo are trademarks or registered trademarks of Extreme Networks, Inc. in the United States and/or other countries.

All other names (including any product names) mentioned in this document are the property of their respective owners and may be trademarks or registered trademarks of their respective companies/owners.

For additional information about Extreme Networks trademarks, go to:

[www.extremenetworks.com/company/legal/trademarks/](http://www.extremenetworks.com/company/legal/trademarks/)

## Support

For product support, including documentation, visit: [www.extremenetworks.com/support/](http://www.extremenetworks.com/support/)

<b>1.0 Introduction</b> .....	<b>5</b>
1.1 Document Conventions .....	5
1.2 Warnings .....	6
1.3 Site Preparation .....	6
1.4 AP-7522E Package Contents .....	6
1.4.1 Features .....	6
1.5 AP-7522E Antennas .....	7
<b>2.0 Hardware Installation</b> .....	<b>9</b>
2.1 Installation Instructions .....	9
2.2 Precautions .....	9
2.3 Access Point Placement .....	9
2.4 Power Injector System .....	10
2.5 Wall Mount Instructions .....	12
2.5.1 Wall Mount Procedure - New Installation .....	13
2.5.2 Wall Mount Procedure - Existing AP Replacement .....	14
2.6 Suspended Ceiling T-Bar Mount Installation .....	15
2.7 LED Indicators .....	18
<b>3.0 Basic Access Point Configuration</b> .....	<b>20</b>
<b>4.0 AP-7522E Access Point Specifications</b> .....	<b>29</b>
4.1 Electrical Characteristics .....	29
4.2 Physical Characteristics .....	29
4.3 Radio Characteristics .....	30
<b>5.0 Regulatory Information</b> .....	<b>31</b>
5.1 Regulatory Information .....	31
5.2 Wireless Device Country Approvals .....	31
5.2.1 Country Selection .....	32
5.2.2 Frequency of Operation - FCC and IC .....	32
5.3 Health and Safety Recommendations .....	33
5.3.1 Warnings for the use of Wireless Devices .....	34

5.3.2 Potentially Hazardous Atmospheres - Fixed Installations . . .	34
5.3.3 Safety in Hospitals . . . . .	34
5.4 RF Exposure Guidelines . . . . .	35
5.4.1 Safety Information . . . . .	35
5.4.2 International . . . . .	35
5.4.3 EU . . . . .	35
5.4.4 US and Canada . . . . .	35
5.5 Power Supply. . . . .	36
5.6 Radio Frequency Interference Requirements - FCC . . . . .	36
5.6.1 Radio Transmitters - Part 15 . . . . .	36
5.6.2 Radio Frequency Interference Requirements - Canada. . . . .	36
5.7 CE Marking and European Economic Area (EEA) . . . . .	37
5.8 Statement of Compliance . . . . .	38
5.9 Japan (VCCI) - Voluntary Control Council for Interference . . . . .	38
5.10 Korea Warning Statement for Class B ITE . . . . .	38
5.11 Other Countries . . . . .	38
5.12 Waste Electrical and Electronic Equipment (WEEE) . . . . .	40
5.13 Turkish WEEE Statement of Compliance . . . . .	41
<b>6.0 Support . . . . .</b>	<b>42</b>
<b>7.0 Symbol Technologies End-User Software License Agreement .43</b>	<b>43</b>
<b>8.0 AP-7522E Access Point China ROHS Compliance . . . . .</b>	<b>50</b>

# 1 Introduction

The AP-7522E external antenna and internal antenna Access Point's are mid-tier Access Point's with a relatively small footprint which supports functionality for dependable and efficient network performance. The AP-7522E is a 2x2:2 802.11ac Access Point utilizing one 2.4 GHz 802.11n radio and one 5 GHz 802.11ac radio. The Access Point housing is Plenum-rated (UL2043).

The Access Point's unique WiNG 5 software enables the Access Point to function as either a *Standalone Access Point*, an *Adaptive Access Point*, or a *Virtual Controller*.

If new to Access Point technology, refer to the *WiNG Access Point System Reference Guide* to familiarize yourself with Access Point technology and the feature set supported by the WiNG operating system. The guide is available at [www.zebra.com/support](http://www.zebra.com/support).

This document is written for the qualified network device installer.

## 1.1 Document Conventions

The following graphical alerts are used in this document to indicate notable situations:



**NOTE** Tips, hints, or special requirements that you should take note of.

---



**CAUTION** Care is required. Disregarding a caution can result in data loss or equipment malfunction.

---



**WARNING!** Indicates a condition or procedure that could result in personal injury or equipment damage.

---

## 1.2 Warnings

- Read all installation instructions and site survey reports, and verify correct equipment installation before connecting the AP-7522E Access Point.
- Remove jewelry and watches before installing this equipment.
- Verify any device connected to this unit is properly wired and grounded.
- Verify there is adequate ventilation around the device, and that ambient temperatures meet equipment operation specifications.

## 1.3 Site Preparation

- Consult your site survey and network analysis reports to determine specific equipment placement, power drops, and so on.
- Assign installation responsibility to the appropriate personnel.
- Identify and document where all installed components are located.
- Ensure adequate, dust-free ventilation to all installed equipment.
- Identify and prepare Ethernet and console port connections.
- Verify cable lengths are within the maximum allowable distances for optimal signal transmission.

## 1.4 AP-7522E Package Contents

An AP-7522E Access Point is available in external antenna (AP-7522) and internal antenna (AP-7522I) configurations. An AP-7522E ships with the following:

- AP-7522E Access Point
- AP-7522E Installation Guide (*This Guide*)
- Wall mount screws and mounting bracket

### 1.4.1 Features

An AP-7522E Access Point supports the following feature set:

- Two RJ-45 connectors (GE1/POE and Console)
- Two LED indicators
- One 2.4 GHz 802.11n radio and one 5 GHz 802.11ac radio
- 2x2 MIMO, 2 spatial streams

The GE1/POE accepts 802.3at or 802.3af compliant power from an external source.



**NOTE** When operating in a Gigabit Ethernet environment, CAT-5e or CAT-6 cable is recommended for Gigabit operation.

---

## 1.5 AP-7522E Antennas

### 1.5.1 AP-7522E Dual Band 2.4 GHz / 5 GHz Antennas - US

An AP-7522E external antenna Access Point supports the following dual band antenna options for the US:



**NOTE** Per FCC requirement, the use of the Access Point on UNII-1 of 5GHz band requires installers to input antenna elevation gain during configuration if the AP placement is for outdoor coverage. This information can be found in Zebra antenna guide located at [www.zebra.com/support](http://www.zebra.com/support).

<i>Part Number</i>	<i>Antenna Type</i>	<i>2.4 GHZ Gain (dBi)</i>	<i>5 GHZ Gain (dBi)</i>	<i>Elevation Gain for outdoor placement (dBi)</i>
ML-2452-APA2-01	Dipole	3.17	4.85	na*
ML-2452-HPA5-036	Dipole	3	5	-2.56
ML-2452-APAG2A1-01	Dipole	2.7	1.7	na*
ML-2452-HPAG4A6-01	Dipole	4	7.3	5.7
ML-2452-HPA6-01	Dipole	5.3	6.1	4.09
ML-2452-PNL9M3-N36	Polarized-Panel	11	10.7	7.3
ML-2452-PNA5-01R	Panel	5.5	6	5.2
ML-2452-PTA3M3-036	Patch	5	4	na*
ML-2452-VMM5M3-N72	Patch	4.5	5.4	2.9

\* This antenna is for indoor placement only.

### 1.5.2 AP-7522E Dual Band 2.4 GHz / 5 GHz Antennas - EU

An external antenna AP-7522E supports the following dual band antenna options for the EU:

<i>Part Number</i>	<i>Antenna Type</i>	<i>2.4 GHZ Gain (dBi)</i>	<i>5 GHZ Gain (dBi)</i>
ML-2452-APA2-01	Dipole	3.17	4.85
ML-2452-HPA5-036	Dipole	3	5
ML-2452-APAG2A1-01	Dipole	2.7	1.7
ML-2452-HPAG4A6-01	Dipole	4	7.3
ML-2452-HPA6-01	Dipole	5.3	6.1

<b>Part Number</b>	<b>Antenna Type</b>	<b>2.4 GHZ Gain (dBi)</b>	<b>5 GHZ Gain (dBi)</b>
ML-2452-PNL6M3-N36	Polarized-Panel	6	6
ML-2452-PNA5-01R	Panel	5.5	6
ML-2452-PTA3M3-036	Patch	5	4
ML-2452-VMM5M3-N72	Patch	4.5	5.4

### 1.5.3 AP-7522E Internal Antenna Model

An AP-7522E internal antenna Access Point supports the following dual band antenna:

<b>Antenna Type</b>	<b>2.4 GHZ Gain (dBi)</b>	<b>5 GHZ Gain (dBi)</b>
PIFA	4.13	5.92

### 1.5.4 AP-7522E Dual Band 2.4 GHz / 5 GHz Antennas - Canada

An external antenna AP-7522E supports the following dual band antennas for Canada:

<b>Part Number</b>	<b>Antenna Type</b>	<b>2.4 GHZ Gain (dBi)</b>	<b>5 GHZ Gain (dBi)</b>
ML-2452-APA2-01	Dipole	3.17	4.85
ML-2452-HPA5-036	Dipole	3	5
ML-2452-APAG2A1-01	Dipole	2.7	1.7
ML-2452-HPAG4A6-01	Dipole	4	7.3
ML-2452-HPA6-01	Dipole	5.3	6.1
ML-2452-PNL9M3-N36	Polarized-Panel	11	10,7
ML-2452-PNA5-01R	Panel	5.5	6
ML-2452-PTA3M3-036	Patch	5	4
ML-2452-VMM5M3-N72	Patch	4.5	5.4

**NOTE** A professional installer must enter the antenna type, gain, and indoor/outdoor placement using the CLI. The AP software will then use this information and hardcode maximum limits determined during testing to limit the EIRP. Please note that the maximum EIRP in band 5.25-5.35GHz will be limited to 23dBm. This limit is hardcoded in the software for this band.





## 2 Hardware Installation

### 2.1 Installation Instructions

An AP-7522E Access Point mounts either on a wall (with *M 3.5 x 0.6 x 23 MM* pan head screws and mounting bracket- or equivalent) or on a suspended ceiling T-bar.

To prepare for the installation:

1. Match the part number on the purchase order with the part numbers in the packing list and on the case of the Access Point.
2. Verify the contents of the box include the intended AP-7522E Access Point, and the included hardware matches the package contents (see [AP-7522E Package Contents on page 6](#)).

<i>Part Number</i>	<i>Description</i>
AP-7522E-67040-US	AP-7522E dual radio 802.11ac 2x2:2 MIMO Access Point external antenna US version
AP-7522E-67040-WR	AP-7522E dual radio 802.11ac 2x2:2 MIMO Access Point external antenna International version
AP-7522E-67040-EU	AP-7522E dual radio 802.11ac 2X2:2 MIMO Access Point external antenna EU version
AP-7522E-67030-US	AP-7522E dual radio 802.11ac 2x2:2 MIMO Access Point internal antenna US version
AP-7522E-67030-WR	AP-7522E dual radio 802.11ac 2x2:2 MIMO Access Point internal antenna International version
AP-7522E-67030-EU	AP-7522E dual radio 802.11ac 2X2:2 MIMO Access Point internal antenna EU version

3. Review site survey and network analysis reports to determine the location and mounting position for the AP-7522E Access Point.
4. Connect a CAT-5 or better Ethernet cable to a compatible 802.3at or 802.3af power source and run the cable to the installation site. Ensure there is sufficient slack on the cable to perform the installation steps.



**NOTE** When operating in a Gigabit Ethernet environment, CAT-5e or CAT-6 cable is recommended for Gigabit operation.

## 2.2 Precautions

Before installing an AP-7522E Access Point, verify the following:

- You are using the correctly rated power solution for the AP-7522E (either the AP-PSBIAS-2P3-ATR power injector or the PWRS-14000-54R external power supply)
- Do not install the AP-7522E in wet or dusty areas.
- Verify the environment has a continuous temperature range between -4° F to 104° F/-20° C to 40° C for external antenna Access Points and 32° F to 104° F/0° C to 40° C for internal antenna Access Points.

## 2.3 Access Point Placement

For optimal performance, install the Access Point away from transformers, heavy-duty motors, fluorescent lights, microwave ovens, refrigerators and other industrial equipment. Signal loss can occur when metal, concrete, walls or floors block transmission. Install the Access Point in an open area or add Access Points as needed to improve coverage.

Antenna coverage is analogous to lighting. Users might find an area lit from far away to be not bright enough. An area lit sharply might minimize coverage and create *dark areas*. Uniform antenna placement in an area (like even placement of a light bulb) provides even, efficient coverage.

Install the Access Point at an ideal height of 10 feet from the ground.

To maximize the Access Point's radio coverage area, conduct a site survey to define and document radio interference obstacles before installing the Access Point.

## 2.4 Power Injector System

An AP-7522E Access Point can receive power via an Ethernet cable connected to the GE1/POE (LAN) port.

When users purchase a WLAN solution, they often need to place Access Points in obscure locations. In the past, a dedicated power source was required for each Access Point in addition to the Ethernet infrastructure. This often required an electrical contractor to install power drops at each Access Point location. The Power Injector merges power and Ethernet into one cable, reducing the burden of installation and allowing optimal Access Point placement in respect to the intended coverage area.



**CAUTION** Using a non-compliant injector, or an injector supporting legacy modes will not allow the AP-7522E to function at optimum performance levels.

---

---



**CAUTION** Do not plug the AP-PSBIAS-2P3-ATR Power Injector into the Access Point's Console port. Connecting the Power Injector into the console port can damage the port and void the AP-7522E's product warranty.

---

---

The AP-7522E's supported Power Injector (Part No. AP-PSBIAS-2P3-ATR) is a high power POE Injector delivering up to 30 watts. The Access Point can only use a Power Injector when connecting the unit to the Access Point's GE1/POE port. The Power Injector is separately ordered and not shipped with an existing AP SKU.

The Access Point Power Supply (Part No. PWRS-14000-54R) is not included with the Access Point and is orderable separately as an accessory. If the Access Point is provided both POE power and PWRS-14000-54R power concurrently, the Access Point will source power from the PWRS-14000-54R supply only. Disconnecting the AC power from the PWRS-14000-54R causes the Access Point to re-boot before sourcing power from the POE power injector. If the AP is operating using injector supplied power, the AP will not automatically reboot if an AC adapter is connected. The Access Point continues to operate with power supplied from the AC adapter without change to the Access Point operating configuration. If using AC adapter supplied power and a change to the AP's operating configuration is warranted, the Access Point needs to be manually rebooted by the customer.



**CAUTION** The Access Point supports any standards-based compliant power source. However, using the wrong solution (including a POE system used on an Access Point) could either limit functionality or severely damage the Access Point and void the product warranty.

---

---

A separate Power Injector is required for each AP-7522E Access Point comprising the network.

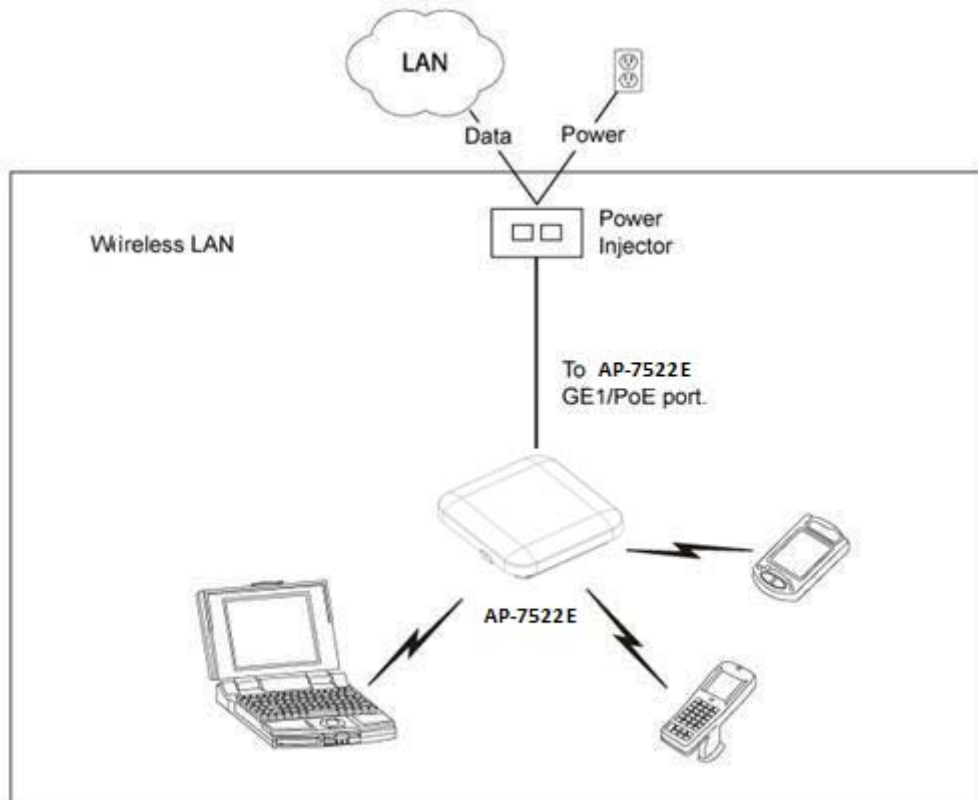

The Power Injector can be installed free standing, on an even horizontal surface or wall mounted using the power injector's wall mounting key holes. The following guidelines should be adhered to before cabling the Power Injector to an Ethernet source and an Access Point:

- Do not block or cover airflow to the Power Injector.
- Keep the Power Injector away from excessive heat, humidity, vibration and dust.
- The Power Injector isn't a repeater, and does not amplify the Ethernet signal. For optimal performance, ensure the Power Injector is placed as close as possible to the data port.



**CAUTION** To avoid problematic performance and restarts, disable POE from a wired switch port connected to an Access Point if mid-span *power sourcing equipment* (PSE) is used between the two, regardless of the manufacturer of the switch.



**CAUTION** Ensure AC power is supplied to the Power Injector using an AC cable with an appropriate ground connection approved for the country of operation.

---

---

To install the Power Injector to an Ethernet data source and an Access Point:

1. Connect the Power Injector to an AC outlet (110VAC to 220VAC).
2. Connect an RJ-45 Ethernet cable between the Power Injector **Data & Power Out** connector and the Access Point's GE1/POE port.
3. Connect an RJ-45 Ethernet cable between the network data supply (host) and the Power Injector **Data In** connector.

Ensure the cable length from the Ethernet source (host) to the Power Injector and Access Point does not exceed 100 meters (333 ft).

The Power Injector has no On/Off power switch. The Injector receives power and is ready for device connection and operation as soon as AC power is applied. Refer to the *Installation Guide* shipped with the Power Injector for a description of the LEDs.

## 2.5 Wall Mount Instructions

A wall mount deployment requires hanging the AP-7522E Access Point with the provided mounting bracket and two screws. The AP-7522E can be mounted on to any plaster, wood or cement wall surface using the provided mounting bracket.

The hardware required to install the AP-7522E on a wall consists of:

- Two wide-shoulder Phillips pan head self-tapping screws (M3.5 x 0.6 x 23 mm)
- Mounting bracket

Optional customer provided installation tools include:

- Phillips head screw driver, or drill and drill bit

### 2.5.1 Wall Mount Procedure - New Installation

This section describes a new AP-7522E installation with no previous Access Point existing on the intended wall surface.

1. Place the mounting bracket against the wall.
2. Mark the screw hole locations depending on the intended deployment orientation of the unit.



**NOTE** When pre-drilling a hole the recommended hole size is 4mm (0.16in.).

---

3. At each point, drill a hole in the wall and attach the mounting bracket.

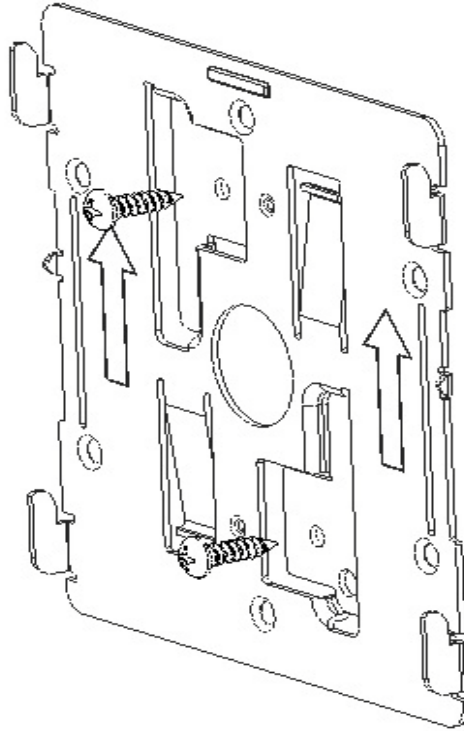

4. Place the Access Point on the mounting bracket.
5. Cable the Access Point using either the Power Injector solution (AP-PSBIAS-2P3-ATR) or the approved AP-7522E power supply (PWRS-14000-54R).  
For Power Injector installations:
  - a. Connect a RJ-45 CAT5e (or CAT6) Ethernet cable between the Power Injector **Data & Power Out** connector and the Access Point's GE1/POE port.
  - b. Connect a RJ-45 CAT5e (or CAT6) Ethernet cable between the network data supply (host) and the Power Injector **Data In** connector.
  - c. Ensure the cable length from the Ethernet source (host) to the Power Injector and Access Point does not exceed 100 meters (333 ft). The Power Injector has no On/Off power switch. The Power Injector receives power as soon as AC power is applied.

For standard power adapter (non Power Injector) and line cord installations:

- a. Connect a RJ-45 Ethernet cable between the network data supply (host) and the Access Point's GE1/POE port.
  - b. Verify the power adapter is correctly rated according to the country of operation.
  - c. Connect the power supply line cord to the power adapter.
  - d. Attach the power adapter cable into the power connector on the Access Point.
  - e. Attach the power supply line cord to a power supply.
6. Verify the Access Point is receiving power by observing the LEDs are lit or flashing. For more information on AP-7522E LED behavior, see [LED Indicators on page 19](#).
  7. The Access Point is ready to configure.



---

---

**CAUTION** If not using an AP-PSBIAS-2P3-ATR power injector, ensure only the AP-7522E's designated power supply (PWRS-14000-54R) is used to supply power to the Access Point. Using an incorrectly rated power supply could damage the Access Point and void the product warranty. Do not actually connect to the power source until the cabling portion of the installation is complete.

---

---

### **2.5.2 Wall Mount Procedure - Existing Access Point Replacement**

An existing AP-7131 or AP-7131N Series Access Point installed on a wall can be replaced by an AP-7522E. Simply remove the existing AP-7131 or AP-7131N and install the new provided mounting bracket for AP-7522E directly to the wall. The cabling procedure for such a replacement is as described in the previous section.

## 2.6 Suspended Ceiling T-Bar Mount Installation

Ceiling mount requires holding the AP-7522E up against a T-bar of a suspended ceiling grid and twisting the unit on to the T-bar. If deploying the AP-7522E on a sculpted ceiling T-Bar, the Access Point mounting kit (Part No. KT-135628-01) can optionally be used as well.

1. First install the mounting bracket on the T-bar then attach the mounting plate using the mounting slots on the Access Point.

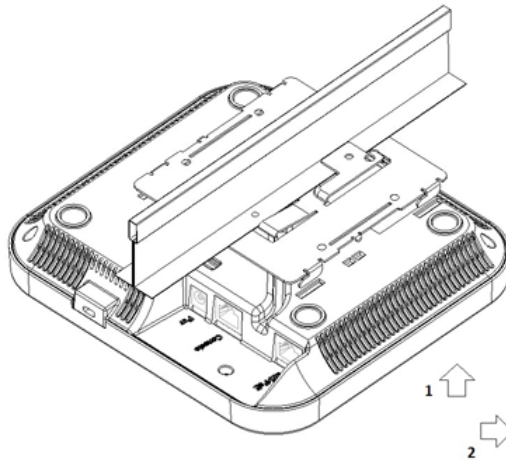
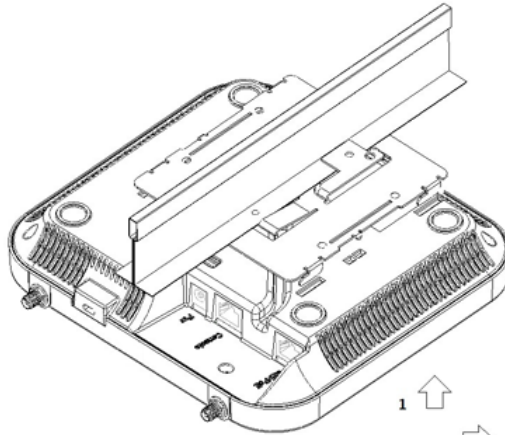

2. Cable the Access Point using either the Power Injector solution (AP-PSBIAS-2P3-ATR) or the approved AP-7522E power supply (PWRS-14000-54R).



For Power Injector installations:

- a. Connect a RJ-45 CAT5e (or CAT6) Ethernet cable between the network data supply (host) and the Power Injector **Data In** connector.
- b. Connect a RJ-45 CAT5e (or CAT6) Ethernet cable between the Power Injector **Data & Power Out** connector and the Access Point's GE1/POE port.
- c. Ensure the cable length from the Ethernet source (host) to the Power Injector and Access Point does not exceed 100 meters (333 ft). The Power Injector has no On/Off power switch. The Power Injector receives power as soon as AC power is applied.

For standard power adapter (non Power Injector) and line cord installations:

- a. Connect a RJ-45 Ethernet cable between the network data supply (host) and the Access Point's GE1/POE port.
- b. Verify the power adapter is correctly rated according the country of operation.
- c. Connect the power supply line cord to the power adapter.
- d. Attach the power adapter cable into the power connector on the Access Point.
- e. Attach the power supply line cord to a power supply.



**CAUTION** If not using an AP-PSBIAS-2P3-ATR power injector, ensure only the AP-7522E's designated power supply (PWRS-14000-54R) is used to supply power to the Access Point. Using an incorrectly rated power supply could damage the Access Point and void the product warranty. Do not actually connect to the power source until the cabling portion of the installation is complete.

---

---

3. Verify the unit has power by observing the LEDs. For more information on AP-7522E LED behavior, see [LED Indicators on page 19](#).
4. Align the bottom of the ceiling T-bar with the back of the Access Point.
5. Orient the Access Point chassis by its length and the length of the ceiling T-bar.
6. Rotate the Access Point chassis 45 degrees clockwise.
7. Push the back of the Access Point chassis on to the bottom of the ceiling T-bar.

8. Rotate the Access Point chassis 45 degrees counter-clockwise. The clips click as they fasten to the T-bar.

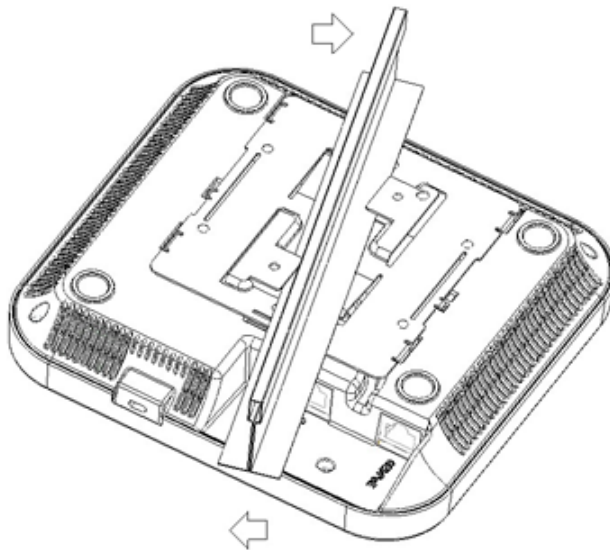
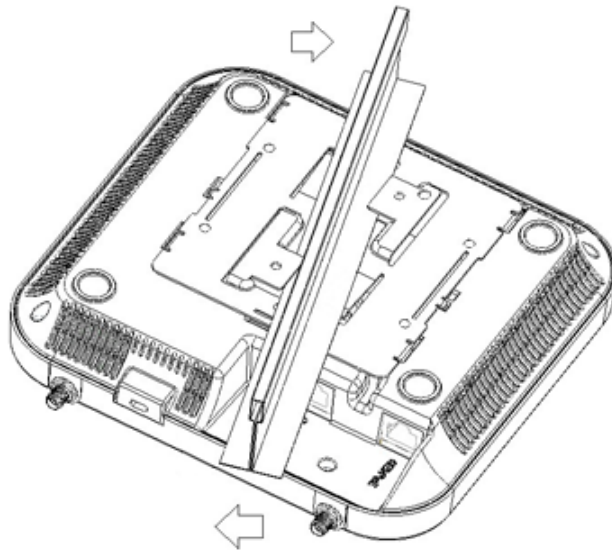

9. The Access Point is ready to configure.

## 2.7 LED Indicators

The AP-7522E LED activity indicators are located on the front of the housing and are visible through the enclosure.

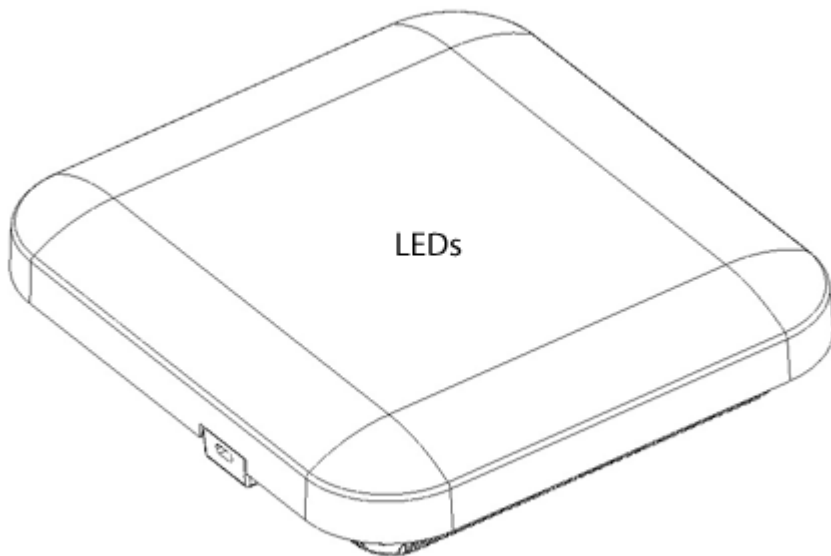
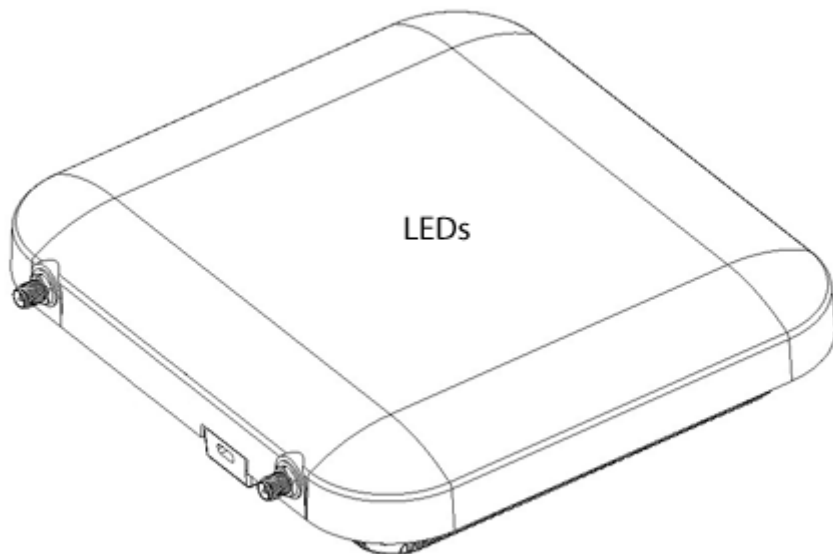

The LEDs provide a status display indicating error conditions, transmission, and network activity for the 5 GHz 802.11ac (amber) radio and the 2.4 GHz 802.11n (green) radio.

<b>Task</b>	<b>5 GHz Activity LED (Amber)</b>	<b>2.4 GHz Activity LED (Green)</b>
Unconfigured Radio	On	On
Normal Operation	<ul style="list-style-type: none"> <li>• If this radio band is enabled: Blink at 5 second interval</li> <li>• If this radio band is disabled: Off</li> <li>• If there is activity on this band: Blink interval at 1 time per second</li> </ul>	<ul style="list-style-type: none"> <li>• If this radio band is enabled: Blink at 5 second interval</li> <li>• If this radio band is disabled: Off</li> <li>• If there is activity on this band: Blink interval at 1 time per second</li> </ul>
Firmware Update	On	Off
Locate AP Mode	LEDs blink in an alternating green, red and amber pattern using an irregular blink rate. This LED state in no way resembles normal operating conditions.	LEDs blink in an alternating green, red and amber pattern using an irregular blink rate. This LED state in no way resembles normal operating conditions

### 3 Basic Access Point Configuration

For a WiNG Express SKU (AP7522E), both the WiNG Express UI and an *over the air* (OTA) provisioning configuration are required for a basic setup and network connection. For a non WiNG Express SKU (AP7522), there's no OTA support, and the Access Point utilizes just the UI for its basic setup.



**NOTE** For information on using WiNG Express beyond this initial setup, refer to the *WiNG Express Users Guide* to familiarize yourself with the WiNG Express Access Point operating system. The guide is available at [www.zebra.com/support](http://www.zebra.com/support).

To provide the Access Point a basic configuration and access WiNG Express management functions:

1. Power up the Access Point.

The Access Point can be powered using an appropriately rated power adapter, POE injector or POE switch resource.

2. Connect to the Access Point.

*For WiNG Express models:*

Connect to the WiNG Express SSID. For Windows systems, locate the SSID by selecting the network icon on the bottom right corner of the screen. For MAC systems, locate the SSID by selecting the network icon on the top right corner of the screen.

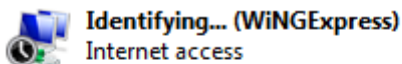

Wireless Network Connection 2

WiNGExpress **Connected**

Open a browser (Chrome, Firefox or Internet Explorer) and enter <http://express.zebra.com>. The login screen displays.

*For non-WiNG Express models:*

Refer to the bottom of the Access Point to obtain the numeric IP address used for connecting to the device. Point the Web browser to the Access Point's IP address. The login screen displays.

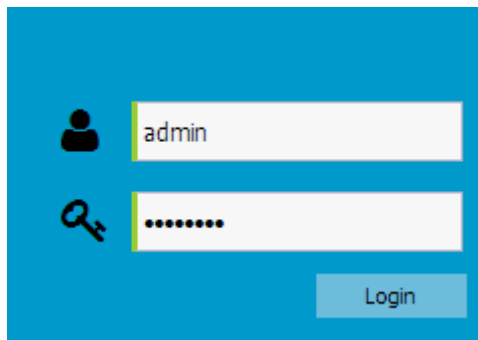
A login form with a blue background. It features a user icon on the left of a text input field containing 'admin'. Below it is a key icon on the left of a password input field containing seven dots. A 'Login' button is positioned at the bottom right of the form.

3. Enter the default username *admin* in the **Username** field.
4. Enter the default password *admin123* in the **Password** field.
5. Select the **Login** button to load the management interface.

If this is the first time the WING Express interface has been accessed, a screen displays prompting for the Access Point's country code.

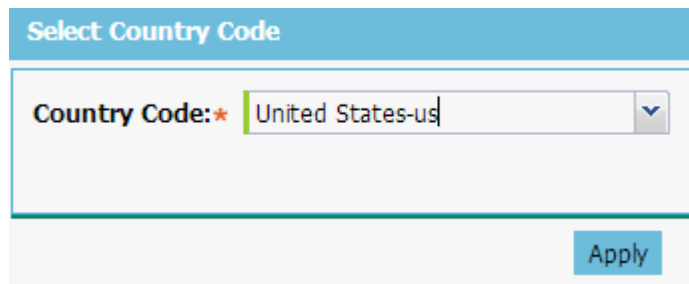
A form titled 'Select Country Code' with a blue header. It contains a dropdown menu labeled 'Country Code: \*' with 'United States-us' selected. An 'Apply' button is located at the bottom right of the form.

6. Select the **Country Code** specific to this Access Point's deployment location.

Selecting the correct country is central to legal operation. Each country has its own regulatory restrictions concerning electromagnetic emissions and the maximum RF signal strength that can be transmitted. Select **Apply** to implement the selected Country Code. SKU's only support certain countries (for example: a US SKU only includes US, Guam, Puerto Rico, American Samoa, US Virgin Islands and Mariana Island).

The Access Point automatically displays a **Dashboard** where users can assess network health and conduct a diagnostic review of Access Point performance.



**NOTE** At some point in the Access Point's initial setup, the default password should be changed to enhance the security of the Access Point and WiNG Express managed network. Refer to the *Configuration > Management* screen to change the default password to a more secure password.

7. Expand the **Configuration** menu item and select **Basic**.

Basic Configuration Settings

AP Name:★ AN-08-15E54C

Country Code:★ Select a Country

Virtual Controller:

Timezone: Select a Timezone

Date & Time: 05/12/2014 Hour: 1 Mins: 34  AM  PM

NTP Server: . . .

Apply Discard

8. Set the following **Basic Configuration Settings** for this Access Point:
  - *AP Name* - Provide an AP Name used as this Access Point's WiNG Express network identifier. If setting this Access Point as a Virtual Controller, each Access Point managed by this Virtual Controller lists this Access Point's AP Name as its own. The AP Name is a required parameter.
  - *Country Code* - If the Country Code was not set when the Access Point was initially powered on, set the country now to ensure the Access Point's legal operation. The Access Point's wireless capabilities are disabled until the required country code is set.
  - *Virtual Controller* - Select this option to define this Access Point as a Virtual Controller capable of managing and provisioning up to 24 Access Points of the same type. If selecting this Access Point as a Virtual Controller, those Access Points managed by this Virtual Controller will list this Access Point's AP Name as its own. Only one Virtual Controller can be designated.

- *Timezone* - Use the drop-down menu to specify the geographic timezone where the Access Point is deployed. Different geographic time zones have daylight savings clock adjustments, so specifying the timezone correctly is important to account for geographic time changes.
- *Date & Time* - Set the date, hour and minute for the Access Point's current system time. Specify whether the current time is in the *AM* or *PM*.
- *NTP Server* - Optionally provide the IP address of a NTP server resource. *Network Time Protocol* (NTP) manages time and/or network clock synchronization within the WiNG Express network. NTP is a client/server implementation. Access Points (NTP clients) periodically synchronize their clock with a master clock (an NTP server). For example, an Access Point resets its clock to 07:04:59 upon reading a time of 07:04:59 from its designated NTP server.

9. Select **Apply** to implement the updates.

10. Expand the **Configuration** menu item and select **WAN**.

WAN Settings

---

Enable:

Port: ge1

Interface: vlan1

DHCP Client  Static IP  PPPoE Settings

Static IP/Mask: \*    / 24

Primary DNS:

Secondary DNS:

Default Gateway:

11. Refer to the **WAN Settings** field and set the following:

- *Enable* - Select this option to allow a connection between the Access Point and a larger network or outside world through the WAN port. Disable this option to isolate the WAN connection. No connections to a larger network or Internet are possible. Clients cannot communicate beyond configured subnets. Both the physical *Port* used to connect to the WAN and the virtual *Interface* (VLAN) are also listed and fixed.
- *DHCP Client* - Select this option to enable DHCP for the Access Point WAN connection. This is useful, if the target network or *Internet Service Provider* (ISP)



uses DHCP. DHCP is a protocol that includes mechanisms for IP address allocation and delivery of host-specific configuration parameters from a DHCP server to a host. Some of these parameters are IP address, network mask, and gateway. The WAN and LAN ports should not both be configured as DHCP clients.

- *Static IP* - Select this option to bypass DHCP address allocation resources and manually set the IP address for the Access Point's WAN connection. Manually provide the Access Point's Static IP/Mask and Default Gateway.
- *PPPoE Settings* - Optionally enable *Point-to-Point Protocol over Ethernet* (PPPoE) on the WAN network. If PPPoE is enabled, provide the required *Auth Type*, *Login Name* and *Login Password*. Server Name and Default Gateway are optional settings. PPP is a data-link protocol for dialup connections allowing an Access Point to use a broadband modem (DSL, cable modem, etc.) for access to high-speed data and broadband networks. Most DSL providers support (or deploy) the PPPoE protocol. PPPoE uses standard encryption, authentication, and compression as specified by the PPPoE protocol. PPPoE enables the Access Point to establish a point-to-point connection to an ISP over an existing Ethernet interface.
- *Static IP / Mask* - Specify an IP address for the WAN connection if using static address assignment for the WAN port. An IP address uses a series of four numbers expressed in dot notation, for example, 190.188.12.1. Additionally, specify a Mask for the access point's WAN connection. This number is available from the ISP for a DSL or cable-modem connection, or from an administrator if the Access Point connects to a larger network.
- *Primary/Secondary DNS/Default Gateway* - If using a static IP or DHCP, enter the Primary and Secondary DNS server resource's numerical IP address and Default Gateway.



**NOTE** If segmenting traffic between the Access Point's WAN and LAN, you'll need to create a VLAN. Complete steps 13 and 14 to define the required VLAN. Otherwise, proceed to step 15.

---

12. Select **Apply** to implement the updates.

13. Expand the **Configuration** menu item and select **Access Points**. Each **AP Name** displays as a link that can be selected to update the configuration of that specific

Access Point. Select a target AP Name link from amongst those displayed in the Access Points screen.

**Edit -> AN-08-15E54C**

---

**Basic Settings**

AP Name :\* AN-08-15E54C

Location : SEQUOIA-CONF

Version : 5.5.3.0-027D

Model : AP-7532-67030-US

UP Time : 0 days, 01 hours 08 minutes

---

**LAN IP Interface Settings**

+ Add | - Delete

<input checked="" type="checkbox"/>	Interface (1-4094)	Description	Static IP
	VLAN*		0.0.0.0/24

Update Cancel

Refer to the **LAN IP Interface Settings** field, and add a VLAN and Static IP as required for enabling DHCP (within the *Configuration > Services* screen) for client IP address requests and ensuring routable traffic.

14. Select **Apply** to commit the updates to the selected Access Point's configuration.
15. Expand the **Configuration** menu item and select **Wireless**.

The Wireless screen displays fields where *Radio Settings* and *Wireless LAN* settings can be defined. Its recommended default radio settings remain as is for the Access Point's basic setup. For information on using WiNG Express beyond this initial setup, refer to the *WiNG Express Users Guide*. The guide is available at [www.zebra.com/support](http://www.zebra.com/support).

In respect to the **Radio Settings**, the professional installer should be aware of the following:

2.4Ghz	Channel: <input type="text" value="smart"/>	Power: <input checked="" type="radio"/> Smart <input type="radio"/> 0 dBm	Antenna Gain:★ <input type="text" value="0"/> dBi
5Ghz	Channel: <input type="text" value="smart"/>	Power: <input checked="" type="radio"/> Smart <input type="radio"/> 0 dBm	Antenna Gain:★ <input type="text" value="0"/> dBi



**NOTE** The above example includes a field for setting the antenna gain. This setting is only available for external antenna Access Points and does not display for internal antenna Access Points.

- The **Channels** available for configuration are channels for which the product is approved in its selected country. The professional installer must ensure the product is set to operate under conditions, and on channels, approved by country regulations.
- Selecting **Smart** as the **Power** setting automatically configures radio power to not exceed the maximum power allowed by the defined country. For static power settings, the professional installer must ensure the configured power levels are compliant with local and regional regulations. The county selected automatically limits the maximum output power that can be set.
- For external antenna Access Points, configure the **Antenna Gain** based on the antenna used in the deployment. The set gain value should include the antenna gain, along with any additional components, such as extension cables used between the Access Point and the antenna.

In respect to the **Wireless LAN** settings, the professional installer should be aware WiNG Express Access Points ship with a default WLAN (WINGExpress). However, this WLAN does not provide adequate authentication to protect from unauthorized user access. recommends an additional WLAN configuration be created and validated before deleting default WLAN.

## Wireless LAN

+ Add   Delete		Row Count: 1					
<input type="checkbox"/>	Name	Enable	SSID	VLAN	Authentication Type	2.4GHz	5GHz
<input type="checkbox"/>	<u>WINGExpress</u>	✓	WINGExpress	2100	captive	✓	✗

16. To create a new WLAN, select + **Add** from the upper, left-hand side of the **Wireless LAN** field.

Wireless LAN

Name:\*

Enable:

SSID:\*   Client-To-Client Communication

Security:  Open  
 Secure-PSK  
 Secure-802.1x  
 Guest

Band:  2.4 GHz  5 GHz

VLAN:\*  (1 - 4094)

Description:

17. Set the following configuration attributes for the new WLAN:

- *Name* - Provide a unique name for the WLAN as its WiNG Express network identifier. This is a required setting.
- *Enable* - Select this setting to enable this WLAN within the WiNG Express managed Access Point network and to provide some measure of data protection not available in the default WLAN.
- *SSID* - Specify the WLAN's SSID. The WLAN SSID is case sensitive and alphanumeric. SSID length should not exceed 32 characters. This is a required setting. Select **Client-To-Client Communication** to enable client interoperability within this WLAN. The default is disabled, meaning clients are *not* allowed to exchange packets with other clients. It does not necessarily prevent clients on other WLANs from sending packets to this WLAN, but if this setting is disabled on the other WLAN, clients are not permitted to interoperate at all.
- *WLAN Type* - The screen displays with the **Open** option selected. Naming and saving such a policy (as is) would provide no security and might only make sense in a network wherein no sensitive data is either transmitted or received. This default setting is *not* recommended.

If selecting **Secure-PSK**, enter a **WPA2 Key** to password protect the WLAN. Define whether the key is entered in ASCII or HEX characters. Selecting *Show* to expose the key is not recommended.

If selecting **Secure-802.1x**, provide an IP address (or hostname) and a shared secret (password) used to access an external RADIUS server resource designated to validate user requests to the Access Point's WLAN resources.

Selecting **Guest** displays fields for captive portal Web page creation, and is beyond the scope of this basic WiNG Express Access Point configuration.

- *Band* -Select the 2.4 GHz and/or 5 GHz radio bands supports by the WiNG Express managed Access Point and its connected client traffic. If this Access Point is designated as a Virtual Controller AP, both radio bands should be enabled.
- *VLAN* - Use the spinner control to specify a VLAN from 1 - 4,094 for this WLAN. When a client associates with a WLAN, the client is assigned a VLAN by load balance distribution. Its recommended you do not use VLAN 1 with the WLAN if the WAN port has been enabled.
- *Description* - Optionally enter a WLAN description to further describe the WLAN's deployment objective within the WiNG Express managed network.

18. Select **Apply** to commit the updates to the Access Point's WLAN configuration.

19. Expand the **Configuration** menu item and select **Services**

DHCP Settings

Enable DHCP Server

+ Add | Delete | Row Count: 0

<input type="checkbox"/>	Interface	IP	Start IP	End IP
--------------------------	-----------	----	----------	--------

Apply | Discard

20. Select **Enable DHCP Server** to ensure the Access Point can provision IP addresses to requesting clients over the specified interface.



**NOTE** A VLAN must be already configured and available to the DHCP server as a viable interface between the Access Point and requesting client. Refer to the **LAN IP Interface Settings** field (within the Edit Access Point screen), and add a VLAN.

---

Select **+ Add** and provide a starting and ending IP range of addresses that constitute a pool of addresses available to requesting clients.

21. Select **Apply** to commit the updates to the Access Point's DHCP configuration.
22. At this point, you're ready to connect to the WiNG Express managed network using the security restrictions applied to the newly created WLAN. Ensure the new secure WLAN has been enabled, and check whether a client is able to access the WiNG Express network.

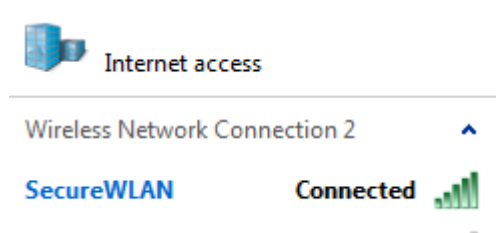

**NOTE** Only when the new WLAN configuration is validated as accessible should the existing WiNG Express default WLAN be deleted.

---

## 4 AP-7522E Access Point Specifications

### 4.1 Electrical Characteristics

An AP-7522E Access Point has the following electrical characteristics:

Operating Current & Voltage	12VDC, 1A (AUX input voltage) 12VDC PWRS-14000-54R power supply 48VDC, 0.375A (POE) 802.3at AP-PSBIAS-2P3-ATR Power Injector
-----------------------------	---

### 4.2 Physical Characteristics

An AP-7522E Access Point has the following physical characteristics:

Dimensions	7.1 in. L x 6.5 in. W x 1.6 in. H 180 mm L x 165 mm W x 41 mm H
Housing	Plenum-rated housing (UL2043)
Weight	1.8 lbs/0.82 kg
Operating Temperature	External antennas: -4° F to 104° F/-20° C to 40° C Internal antennas: 32° F to 104° F/0° C to 40° C
Storage Temperature	-40° F to 158° F/-40° C to 70° C
Operating Humidity	85% RH non-condensing
Operating Altitude (maximum)	8,000 ft @ 28C
Storage Altitude (maximum)	30,000 ft @ 12C
Electrostatic Discharge	External antennas: 12kV air, 6kV contact Internal antennas: 15 kV air, 8kV contact

## 4.3 Radio Characteristics

The AP-7522E Access Point has the following radio characteristics:

Data Rates Supported	802.11b/g: 1,2,5.5,11,6,9,12,18,24,36,48 and 54 Mbps 802.11a: 6,9,12,18,24,36,48, and 54 Mbps 802.11a/n: MCS 0-23 up to 300 Mbps 802.11ac: MCS 0-9 up to 866.7 Gbps Turbo Mode (256QAM) on 2.4 GHz band: up to 400 Mbps
Wireless Medium	<i>Direct Sequence Spread Spectrum (DSSS)</i> <i>Orthogonal Frequency Division Multiplexing (OFDM)</i> <i>Spatial multiplexing (MIMO)</i>
Network Standards	IEEE 802.11a/b/g/n/ac 802.11d and 802.11i WPA2 WMM and WMM-UAPSD
Transmit Power Adjustment	1dB increments



## 5 Regulatory Information

### 5.1 Regulatory Information

This guide applies to the following Model Numbers: AP-7522, AP-7522I.

Zebra devices are designed to be compliant with rules and regulations in locations they are sold and will be labeled as required.

Local language translations are available at the following Website: [www.zebra.com/support](http://www.zebra.com/support)

Any changes or modifications to Zebra equipment, not expressly approved by Zebra could void the user's authority to operate the equipment.

Zebra devices are professionally installed, the Radio Frequency Output Power will not exceed the maximum allowable limit for the country of operation.

Antennas: Use only the supplied or an approved replacement antenna. Unauthorized antennas, modifications, or attachments could cause damage and may violate regulations.

This device is only to be used with a Zebra Technologies Wireless Switch.

Declared maximum operating temperature: 40°C.

### 5.2 Wireless Device Country Approvals

Regulatory markings, subject to certification, are applied to the device signifying the radio(s) is/are approved for use in the following countries: United States, Canada, Japan, China, S. Korea, Australia, and Europe 1

Please refer to the *Declaration of Conformity* (DoC) for details of other country markings. This is available at: [www.zebra.com/doc](http://www.zebra.com/doc)

**Note:** For 2.4GHz or 5GHz Products: Europe includes, Austria, Belgium, Bulgaria, Czech Republic, Cyprus, Denmark, Estonia, Finland, France, Germany, Greece, Hungary, Iceland, Ireland, Italy, Latvia, Liechtenstein, Lithuania, Luxembourg, Malta, Netherlands, Norway, Poland, Portugal, Romania, Slovak Republic, Slovenia, Spain, Sweden, Switzerland and the United Kingdom.



Operation of the device without regulatory approval is illegal.

#### 5.2.1 Country Selection

Select only the country in which you are using the device. Any other selection will make the operation of this device illegal. Some Access Points are specifically designed to operate in certain countries (Example; -US for the United States, -EU for the European Union).

## Country Roaming

This device incorporates the International Roaming feature (IEEE802.11d) which will ensure the product operates on the correct channels for the particular country of use.

### 5.2.2 Frequency of Operation – FCC and IC

#### 5 GHz Only

Industry Canada Statement:

**Caution:** The device for the band 5150-5250 MHz is only for indoor usage to reduce potential for harmful interference to co-Channel mobile satellite systems. High power radars are allocated as primary users (meaning they have priority) of 5250-5350 MHz and 5650-5850 MHz and these radars could cause interference and/or damage to LE-LAN devices.

**Avertissement:** Le dispositif fonctionnant dans la bande 5150-5250 MHz est réservé uniquement pour une utilisation à l'intérieur afin de réduire les risques de brouillage préjudiciable aux systèmes de satellites mobiles utilisant les mêmes canaux.

Les utilisateurs de radars de haute puissance sont désignés utilisateurs principaux (c.-à-d., qu'ils ont la priorité) pour les bandes 5250-5350 MHz et 5650-5850 MHz et que ces radars pourraient causer du brouillage et/ou des dommages aux dispositifs LAN-EL.

#### 2.4 GHz Only

The available channels for 802.11bg operation in the US are Channels 1 to 11. The range of channels is limited by firmware.

## 5.3 Health and Safety Recommendations



### Ergonomic Recommendations

**Caution:** In order to avoid or minimize the potential risk of ergonomic injury follow the recommendations below. Consult with your local Health & Safety Manager to ensure that you are adhering to your company's safety programs to prevent employee injury.

- Reduce or eliminate repetitive motion
- Maintain a natural position
- Reduce or eliminate excessive force
- Keep objects that are used frequently within easy reach
- Perform tasks at correct heights
- Reduce or eliminate vibration
- Reduce or eliminate direct pressure

- Provide adjustable workstations
- Provide adequate clearance
- Provide a suitable working environment
- Improve work procedures

## Vehicle Installation

RF signals may affect improperly installed or inadequately shielded electronic systems in motor vehicles (including safety systems). Check with the manufacturer or its representative regarding your vehicle. You should also consult the manufacturer of any equipment that has been added to your vehicle.

An air bag inflates with great force. DO NOT place objects, including either installed or portable wireless equipment, in the area over the air bag or in the air bag deployment area. If in-vehicle wireless equipment is improperly installed and the air bag inflates, serious injury could result.

Position your device within easy reach. Be able to access your device without removing your eyes from the road.

Note: Connection to an alert device that will cause a vehicle horn to sound or lights to flash, on receipt of a call on public roads, is not permitted.

## IMPORTANT

Before installing or using, check state and local laws regarding windshield mounting and use of equipment.

### For Safe installation

- Do not put your phone in a location that obstructs the drivers vision or interferes with the operation of the Vehicle.
- Do not cover an airbag.

## Safety on the Road

Do not take notes or use the device while driving. Jotting down a "to do" list or flipping through your address book takes attention away from your primary responsibility, driving safely.

When driving a car, driving is your first responsibility - Give full attention to driving. Check the laws and regulations on the use of wireless devices in the areas where you drive. Always obey them.

### 5.3.1 *Warnings for the use of Wireless Devices*



Please observe all warning notices with regard to the usage of wireless devices.

### **5.3.2 Potentially Hazardous Atmospheres – Fixed Installations**

You are reminded of the need to observe restrictions on the use of radio devices in fuel depots, chemical plants etc. and areas where the air contains chemicals or particles (such as grain, dust, or metal powders).

### **5.3.3 Safety in Hospitals**

 Wireless devices transmit radio frequency energy and may affect medical electrical equipment. When installed adjacent to other equipment, it is advised to verify that the adjacent equipment is not adversely affected.

#### **Pacemakers**

Pacemaker manufacturers recommended that a minimum of 15cm (6 inches) be maintained between a handheld wireless device and a pacemaker to avoid potential interference with the pacemaker. These recommendations are consistent with independent research and recommendations by Wireless Technology Research.

#### **Persons with Pacemakers:**

- Should ALWAYS keep the device more than 15cm (6 inches) from their pacemaker when turned ON.
- Should not carry the device in a breast pocket.
- Should use the ear furthest from the pacemaker to minimize the potential for interference.
- If you have any reason to suspect that interference is taking place, turn OFF your device.

#### **Other Medical Devices**

Please consult your physician or the manufacturer of the medical device, to determine if the operation of your wireless product may interfere with the medical device.

## 5.4 RF Exposure Guidelines

### 5.4.1 Safety Information

#### ***Reducing RF Exposure - Use Properly***

Only operate the device in accordance with the instructions supplied.

### 5.4.2 International

The device complies with internationally recognized standards covering human exposure to electromagnetic fields from radio devices. For information on “International” human exposure to electromagnetic fields refer to the *Declaration of Conformity* (DoC) at: [www.zebra.com/doc](http://www.zebra.com/doc)

### 5.4.3 EU

#### ***Remote and Standalone Antenna Configurations***

To comply with EU RF exposure requirements, antennas that are mounted externally at remote locations or operating near users at stand-alone desktop of similar configurations must operate with a minimum separation distance of 20cm from all persons.

### 5.4.4 US and Canada

#### ***Co-located statement***

To comply with FCC RF exposure compliance requirements, the antenna used for this transmitter must not be co-located or operating in conjunction with any other transmitter/antenna except those already approved in this filing.

To satisfy US and Canadian RF exposure requirements, a transmitting device must operate with a minimum separation distance of 30cm or more from a person's body.

Pour satisfaire aux exigences Américaines et Canadiennes d'exposition aux radiofréquences, un dispositif de transmission doit fonctionner avec une distance de séparation minimale de 30cm ou plus de corps d'une personne.

#### Radiation Exposure Statement

This equipment complies with IC radiation exposure limits set forth for an uncontrolled environment. This equipment should be installed and operated with minimum distance 30cm between the radiator and your body.

**NOTE IMPORTANTE:** (Pour l'utilisation de dispositifs mobiles)

Déclaration d'exposition aux radiations:

Cet équipement est conforme aux limites d'exposition aux rayonnements IC établies pour un environnement non contrôlé. Cet équipement doit être installé et utilisé avec un minimum de 30cm de distance entre la source de rayonnement et votre corps.

## **Remote and Standalone Antenna Configurations**

To comply with FCC RF exposure requirements, Antennas that are mounted externally must be professionally installed at a fixed location and operate with a minimum distance of 30cm from all persons.

To comply with FCC Antenna requirements, the Antenna must be adjusted such that the RF emission lobes are below 30 degrees elevation.

## **5.5 Power Supply**

This device must be powered from a 802.3af or 802.3at compliant power source which has been certified by the appropriate agencies, or by a approved UL LISTED ITE (IEC/EN 60950-1, LPS/SELV) power supply with electrical ratings: Output 12 Vdc, min 1.25 A or 48 Vdc min 0.375 A (POE), with a recommended ambient temperature greater than 40 degrees C. Use of alternative power supply will invalidate any approvals given to this unit and may be dangerous.

## **5.6 Radio Frequency Interference Requirements—FCC**



This equipment has been tested and found to comply with the limits for a Class B digital device, pursuant to Part 15 of the FCC rules. These limits are designed to provide reasonable protection against harmful interference in a residential installation. This equipment generates, uses and can radiate radio frequency energy and, if not installed and used in accordance with the instructions, may cause harmful interference to radio communications. However there is no guarantee that interference will not occur in a particular installation. If this equipment does cause harmful interference to radio or television reception, which can be determined by turning the equipment off and on, the user is encouraged to try to correct the interference by one or more of the following measures:

- Reorient or relocate the receiving antenna
- Increase the separation between the equipment and receiver
- Connect the equipment into an outlet on a circuit different from that to which the receiver is connected
- Consult the dealer or an experienced radio/TV technician for help.

### **5.6.1 Radio Transmitters (Part 15)**

This device complies with Part 15 of the FCC Rules. Operation is subject to the following two conditions: (1) this device may not cause harmful interference, and (2) this device must accept any interference received, including interference that may cause undesired operation.

## 5.6.2 Radio Frequency Interference Requirements - Canada

CAC ICES-3 (B)/NMB-3(B)

Radio Transmitters

For RLAN Devices:

The use of 5 GHz RLAN's, for use in Canada, have the following restrictions:

- Restricted Band 5.60 – 5.65 GHz

This device complies with RSS 210 of Industry Canada. Operation is subject to the following two conditions: (1) this device may not cause harmful interference and (2) this device must accept any interference received, including interference that may cause undesired operation.

Le présent appareil est conforme aux CNR d'Industrie Canada applicables aux appareils radio exempts de licence. L'exploitation est autorisée aux deux conditions suivantes : (1) l'appareil ne doit pas produire de brouillage, et (2) l'utilisateur de l'appareil doit accepter tout brouillage radioélectrique subi, même si le brouillage est susceptible d'en compromettre le fonctionnement.

Label Marking: The Term "IC:" before the radio certification only signifies that Industry Canada technical specifications were met

In accordance with the regulations of Industry Canada, this radio transmitter can operate with an antenna of a type and a maximum gain (or lower) approved for the transmitter by Industry Canada. With the aim of reducing the risk of radio interference to other users, the chosen antenna type and its gain should be selected so that the equivalent isotropically radiated power (e.i.r.p.) does not exceed the intensity necessary for the establishment of a satisfactory connection.

Conformément à la réglementation d'Industrie Canada, le présent émetteur radio peut fonctionner avec une antenne d'un type et d'un gain maximal (ou inférieur) approuvé pour l'émetteur par Industrie Canada. Dans le but de réduire les risques de brouillage radioélectrique à l'intention des autres utilisateurs, il faut choisir le type d'antenne et son gain de sorte que la puissance isotrope rayonnée équivalente (p.i.r.e.) ne dépasse pas l'intensité nécessaire à l'établissement d'une communication satisfaisante.

In compliance with respective local regulatory law, the AP software provides professional installers the option to configure the antenna type and antenna gain for approved antennas.

This radio transmitter (AP-7522, AP-7522I) has been approved by Industry Canada to operate with the antenna types listed below and having a maximum gain allowable and the impedance required for each type of antenna. The antenna types not included in this list, or whose gain is higher than the maximum gain indicates, are strictly prohibited for the operation of the transmitter.

Refer to [AP-7522E Antennas on page 7](#) for a listing of the 2.4 GHz and 5 GHz antennas initially approved for use with AP-7522 and AP7522I Access Points.

Le présent émetteur radio (AP-7522, AP-7522I) a été approuvé par Industrie Canada pour fonctionner avec les types d'antenne énumérés ci-dessous et ayant un gain admissible maximal et l'impédance requise pour chaque type d'antenne. Les types d'antenne non inclus dans cette liste ou dont le gain est supérieur au gain maximal indiqué, sont strictement interdits pour l'exploitation de l'émetteur.

## 5.7 CE Marking and European Economic Area (EEA)

 **WARNING:** This is a Class B product. In a domestic environment this product may cause radio interference in which case the user may be required to take adequate measures.

The use of 2.4GHz RLAN's, for use through the EEA, have the following restrictions:

- Maximum radiated transmit power of 100 mW EIRP in the frequency range 2.400 -2.4835 GHz.

## 5.8 Statement of Compliance

Zebra hereby declares that this device is in compliance with the essential requirements and other relevant provisions of Directive 1999/5/EC. A Declaration of Conformity may be obtained from [www.zebra.com/doc](http://www.zebra.com/doc).

## 5.9 Japan (VCCI) - Voluntary Control Council for Interference

Class B ITE

この装置は、情報処理装置等電波障害自主規制協議会（VCCI）の基準に基づくクラスB情報技術装置です。この装置は、家庭環境で使用することを目的としていますが、この装置がラジオやテレビジョン受信機に近接して使用されると、受信障害を引き起こすことがあります。取扱説明書に従って正しい取り扱いをして下さい。

5.2/5.3GHz 屋内使用規定™ or この製品は屋内においてのみ使用可能です

## 5.10 Korea Warning Statement for Class B ITE

기종별	사용자안내문
B급 기기 (가정용 방송통신기자재)	이 기기는 가정용(B급) 전자파적합기기로서 주로 가정에서 사용하는 것을 목적으로 하며, 모든 지역에서 사용할 수 있습니다.



## 5.11 Other Countries

### Australia

Use of 5GHz RLAN's in Australia is restricted in the following band 5.50 – 5.65GHz.

### Brazil

#### Declarações Regulamentares para AP-7522E - Brasil

Nota: A marca de certificação se aplica ao Transceptor, modelo AP-7522E. Este equipamento opera em caráter secundário, isto é, não tem direito a proteção contra interferência prejudicial, mesmo de estações do mesmo tipo, e não pode causar interferência a sistemas operando em caráter primário. Para maiores informações sobre ANATEL consulte o site: [www.anatel.gov.br](http://www.anatel.gov.br)

Este equipamento opera em caráter secundário, isto é, não tem direito a proteção contra interferência prejudicial, mesmo de estações do mesmo tipo, e não pode causar interferência a sistemas operando em caráter primário.

Este produto está homologado pela Anatel, de acordo com os procedimentos regulamentados pela Resolução nº242/2000 e atende aos requisitos técnicos aplicados, incluindo os limites de exposição da Taxa de Absorção Específica referente a campos elétricos, magnéticos e eletromagnéticos de radiofrequência, de acordo com as Resoluções nº 303/2002 e 533/2009.

Este dispositivo está em conformidade com as diretrizes de exposição à radiofrequência quando posicionado pelo menos 25 centímetros de distância do corpo. Para maiores informações, consulte o site da Anatel.

### Chile

Este equipo cumple con la Resolución No 403 de 2008, de la Subsecretaria de telecomunicaciones, relativa a radiaciones electromagnéticas.

### China



### Mexico

Restrict Frequency Range to: 2.450 – 2.4835 GHz.

## S. Korea

무선설비는 운용 중 전파혼신 가능성이 있음

당해 무선설비는 전파혼신 가능성이 있으므로 인명안전과 관련된 서비스는 할 수 없습니다.

## Taiwan

### 臺灣

#### 低功率電波輻射性電機管理辦法

##### 第十二條

經型式認證合格之低功率射頻電機，非經許可，公司、商號或使用者均不得擅自變更頻率、加大功率或變更原設計之特性及功能。

##### 第十四條

低功率射頻電機之使用不得影響飛航安全及干擾合法通信；經發現有干擾現象時，應立即停用，並改善至無干擾時方得繼續使用。

前項合法通信，指依電信規定作業之無線電通信。

低功率射頻電機須忍受合法通信或工業、科學及醫療用電波輻射性電機設備之干擾。

?5.25-5.35 ?????????????????????????????????

電磁波曝露量MPE標準值 $1\text{mW}/\text{cm}^2$ ，本產品使用時建議應距離人體：25 cm

## Thailand

**เครื่องโทรคมนาคมและอุปกรณ์นี้ มีความสอดคล้องตามข้อกำหนดของ กทช.**

## Hong Kong

This equipment is restricted to indoor operation in the 5.15-5.35GHz band for Hong Kong.

## 5.12 Waste Electrical and Electronic Equipment (WEEE)



**English:** For EU Customers: All products at the end of their life must be returned to Zebra for recycling. For information on how to return product, please go to: [www.zebra.com/weee](http://www.zebra.com/weee).

**Français:** Clients de l'Union Européenne: Tous les produits en fin de cycle de vie doivent être retournés à Zebra pour recyclage. Pour de plus amples informations sur le retour de produits, consultez : [www.zebra.com/weee](http://www.zebra.com/weee).

**Español:** Para clientes en la Unión Europea: todos los productos deberán entregarse a Zebra al final de su ciclo de vida para que sean reciclados. Si desea más información sobre cómo devolver un producto, visite: [www.zebra.com/weee](http://www.zebra.com/weee).

**Български:** За клиенти от ЕС: След края на полезния им живот всички продукти трябва да се връщат на Zebra за рециклиране. За информацията относно връщането на продукти, моля отидете на адрес: [www.zebra.com/weee](http://www.zebra.com/weee).

**Deutsch:** Für Kunden innerhalb der EU: Alle Produkte müssen am Ende ihrer Lebensdauer zum Recycling an Zebra zurückgesandt werden. Informationen zur Rücksendung von Produkten finden Sie unter [www.zebra.com/weee](http://www.zebra.com/weee).

**Italiano:** per i clienti dell'UE: tutti i prodotti che sono giunti al termine del rispettivo ciclo di vita devono essere restituiti a Zebra al fine di consentirne il riciclaggio. Per informazioni sulle modalità di restituzione, visitare il seguente sito Web: [www.zebra.com/weee](http://www.zebra.com/weee).

**Português:** Para clientes da UE: todos os produtos no fim de vida devem ser devolvidos à Zebra para reciclagem. Para obter informações sobre como devolver o produto, visite: [www.zebra.com/weee](http://www.zebra.com/weee).

**Nederlands:** Voor klanten in de EU: alle producten dienen aan het einde van hun levensduur naar Zebra te worden teruggezonden voor recycling. Raadpleeg [www.zebra.com/weee](http://www.zebra.com/weee) voor meer informatie over het terugzenden van producten.

**Polski:** Klienci z obszaru Unii Europejskiej: Produkty wycofane z eksploatacji należy zwrócić do firmy Zebra w celu ich utylizacji. Informacje na temat zwrotu produktów znajdują się na stronie internetowej [www.zebra.com/weee](http://www.zebra.com/weee).

**Čeština:** Pro zákazníky z EU: Všechny produkty je nutné po skončení jejich životnosti vrátit společnosti Zebra k recyklaci. Informace o způsobu vrácení produktu najdete na webové stránce: [www.zebra.com/weee](http://www.zebra.com/weee).

**Eesti:** EL klientidele: kõik tooted tuleb nende eluea lõppedes tagastada taaskasutamise eesmärgil Zebra'ile. Lisainformatsiooni saamiseks toote tagastamise kohta külastage palun aadressi: [www.zebra.com/weee](http://www.zebra.com/weee).

**Magyar:** Az EU-ban vásárlóknak: Minden tönkrement terméket a Zebra vállalathoz kell eljuttatni újrahásznotás céljából. A termék visszajuttatásának módjával kapcsolatos tudnivalóért látogasson el a [www.zebra.com/weee](http://www.zebra.com/weee) weboldalra.

**Svenska:** För kunder inom EU: Alla produkter som uppnått sin livslängd måste returneras till Zebra för återvinning. Information om hur du returnerar produkten finns på [www.zebra.com/weee](http://www.zebra.com/weee).

**Suomi:** Asiakkaat Euroopan unionin alueella: Kaikki tuotteet on palautettava kierrätettäväksi Zebra-yhtiöön, kun tuotetta ei enää käytetä. Lisätietoja tuotteen palauttamisesta on osoitteessa [www.zebra.com/weee](http://www.zebra.com/weee).

**Dansk:** Til kunder i EU: Alle produkter skal returneres til Zebra til recirkulering, når de er udtjent. Læs oplysningerne om returnering af produkter på: [www.zebra.com/weee](http://www.zebra.com/weee).

**Ελληνικά:** Για πελάτες στην Ε.Ε.: Όλα τα προϊόντα, στο τέλος της διάρκειας ζωής τους, πρέπει να επιστρέφονται στην Zebra για ανακύκλωση. Για περισσότερες πληροφορίες σχετικά με την επιστροφή ενός προϊόντος, επισκεφθείτε τη διεύθυνση [www.zebra.com/weee](http://www.zebra.com/weee) στο Διαδίκτυο.

**Malti:** Għal klijenti fl-UE: il-prodotti kollha li jkunu waslu fl-aħħar tal-ħajja ta' l-użu tagħhom, iridu jiġu rritornati għand Zebra għar-riċiklaġġ. Għal aktar taġġir dwar kif għandek tirritorna l-prodott, jekk jogħġbok żur:

[www.zebra.com/weee](http://www.zebra.com/weee).

**Românesc:** Pentru clienții din UE: Toate produsele, la sfârșitul duratei lor de funcționare, trebuie returnate la Zebra pentru reciclare. Pentru informații despre returnarea produsului, accesați: [www.zebra.com/weee](http://www.zebra.com/weee).

**Slovenski:** Za kupce v EU: vsi izdelki se morajo po poteku življenjske dobe vrniti podjetju Zebra za reciklažo. Za informacije o vračilu izdelka obiščite: [www.zebra.com/weee](http://www.zebra.com/weee).

**Slovenčina:** Pre zákazníkov z krajín EU: Všetky výrobky musia byť po uplynutí doby ich životnosti vrátené spoločnosti Zebra na recykláciu. Bližšie informácie o vrátení výrobkov nájdete na: [www.zebra.com/weee](http://www.zebra.com/weee).

**Lietuvių:** ES vartotojams: visi gaminiai, pasibaigus jų eksploatacijos laikui, turi būti grąžinti utilizuoti į kompaniją „Zebra“. Daugiau informacijos, kaip grąžinti gaminį, rasite: [www.zebra.com/weee](http://www.zebra.com/weee).

**Latviešu:** ES klientiem: visi produkti pēc to kalpošanas mūža beigām ir jānogādā atpakaļ Zebra otrreizējai pārstrādei. Lai iegūtu informāciju par produktu nogādāšanu Zebra, lūdzu, skatiet: [www.zebra.com/weee](http://www.zebra.com/weee).

**Türkçe:** AB Müşterileri için: Kullanım süresi dolan tüm ürünler geri dönüşürme için Zebra'ya iade edilmelidir. Ürünlerin nasıl iade edileceği hakkında bilgi için lütfen şu adresi ziyaret edin: [www.zebra.com/weee](http://www.zebra.com/weee).

## 5.13 TURKISH WEEE Statement of Compliance

EEE Yönetmeliğine Uygundur

## 6 Support

If you have a problem with your equipment, contact support for your region.

Contact information is available at: [www.zebra.com/support](http://www.zebra.com/support)

When contacting support, please provide the following information:

- Serial number of the unit
- Model number or product name
- Software type and version number

Support responds to calls by e-mail, telephone, or fax within the time limits set forth in support agreements. If you purchased your product from a business partner, contact that business partner for support.

### Customer Support Web Sites

The Support site, located at [www.zebra.com/support](http://www.zebra.com/support) provides information and online assistance including developer tools, software downloads, product manuals and online repair requests.

## 7 Zebra Technologies Corporation ("Zebra") End-User Software License Agreement

BY INSTALLING AND/OR USING THIS PRODUCT, YOU ACKNOWLEDGE THAT YOU HAVE READ THIS AGREEMENT, UNDERSTAND IT AND AGREE TO BE BOUND ITS TERMS. IF YOU DO NOT AGREE TO THE TERMS OF THIS AGREEMENT, ZEBRA IS NOT WILLING TO LICENSE THE PRODUCT TO YOU, AND YOU MUST NOT INSTALL OR USE THIS PRODUCT.

### *Definitions*

### *Grant of License*

Zebra Technologies Corporation ("Zebra") grants you ("Licensee" or "you") a personal, nonexclusive, nontransferable, revocable, nonassignable, limited license to use the software and documentation ("Product(s)") subject to the terms and conditions of this Agreement. You shall use the Products only for your internal business purposes, exclusively to support Zebra devices. Any use of the Products outside of the conditions set forth herein is strictly prohibited and will be deemed a breach of this Agreement resulting in immediate termination of your License. In the event of a breach of this Agreement, Zebra will be entitled to all available remedies at law or in equity (including immediate termination of the license without notice, immediate injunctive relief and repossession of all Products unless Licensee is a Federal agency of the United States Government).

You shall not distribute, sublicense, rent, loan, lease, export, re-export, resell, ship or divert or cause to be exported, re-exported, resold, shipped or diverted, directly or indirectly, the Products under this Agreement. You shall not, and shall not permit others to: (i) modify, translate, decompile, bootleg, reverse engineer, disassemble, or extract the inner workings of the Products, (ii) copy the look-and-feel or functionality of the Products; (iii) remove any proprietary notices, marks, labels, or logos from the Products; (iv) rent or transfer all or some of the Products to any other party without Zebra's prior written consent; or (v) utilize any computer software or hardware which is designed to defeat any copy protection device, should the Products be equipped with such a protection device.

Title to all copies of Products will not pass to Licensee at any time and remains vested exclusively in Zebra. All intellectual property developed, originated, or prepared by Zebra in connection with the Products remain vested exclusively in Zebra, and this Agreement does not grant to Licensee any intellectual property rights.

Portions of the Products are protected by United States patent and copyright laws, international treaty provisions, and other applicable laws. Therefore, you must treat the Products like any other copyrighted material (e.g., a book or musical recording) except that you may make one copy of the Product solely for back-up purposes. Unauthorized duplication of the Products constitutes copyright infringement, and in the United States is punishable in federal court by fine and imprisonment.

### *Limited Warranty*

Zebra warrants for a period of ninety (90) days from your receipt of the Products to you that the Software, under normal use, will perform substantially in accordance with Zebra's published specifications for that release level of the Software. The written materials are provided "AS IS" and without warranty of any kind. Zebra's entire liability and your sole and exclusive remedy for any breach of the foregoing limited warranty will be, at Zebra's option, the provision of a downloadable patch or replacement code, or a refund of the unused portion of your bargained for contractual benefit up to the amount paid for the Products.

### *Disclaimer*

THIS LIMITED WARRANTY IS THE ONLY WARRANTY PROVIDED BY ZEBRA, AND ZEBRA MAKES, AND YOU RECEIVE, NO OTHER WARRANTIES OF ANY KIND, WHETHER EXPRESS, IMPLIED, STATUTORY, OR IN ANY COMMUNICATION WITH YOU. ZEBRA SPECIFICALLY DISCLAIMS ANY WARRANTY INCLUDING THE IMPLIED WARRANTIES OF MERCHANTABILITY, NONINFRINGEMENT, OR FITNESS FOR A PARTICULAR PURPOSE. ZEBRA DOES NOT WARRANT THAT THE PRODUCTS WILL MEET YOUR REQUIREMENTS, OR THAT THE OPERATION OF THE PRODUCTS WILL BE UNINTERRUPTED OR ERROR FREE, OR THAT DEFECTS IN THE PRODUCTS WILL BE CORRECTED. ZEBRA MAKES NO WARRANTY WITH RESPECT TO THE CORRECTNESS, ACCURACY, OR RELIABILITY OF THE PRODUCTS. Some jurisdictions do not allow the exclusion of implied warranties, so the above exclusion may not apply to you.

### *Limitation of Liability*

THE TOTAL LIABILITY OF ZEBRA UNDER THIS AGREEMENT FOR DAMAGES SHALL NOT EXCEED THE FAIR MARKET VALUE OF THE PRODUCTS LICENSED UNDER THIS AGREEMENT. IN NO EVENT WILL ZEBRA BE LIABLE IN ANY WAY FOR INCIDENTAL, CONSEQUENTIAL, INDIRECT, SPECIAL OR PUNITIVE DAMAGES OF ANY NATURE, INCLUDING WITHOUT LIMITATION, LOST BUSINESS PROFITS, OR LIABILITY OR INJURY TO THIRD PERSONS, WHETHER FORESEEABLE OR NOT, REGARDLESS OF WHETHER ZEBRA HAS

BEEN ADVISED OF THE POSSIBILITY OF SUCH DAMAGES. Some jurisdictions do not permit limitations of liability for incidental or consequential damages, so the above exclusions may not apply to you. This Limitation of Liability provision survives the termination of this Agreement and applies notwithstanding any contrary provision in this Agreement. Licensee must bring any action under this Agreement within one (1) year after the cause of action arises.

### ***Maintenance***

Unless provided for in a separate agreement, Zebra shall not be responsible for maintenance or field service of the Products.

### ***High Risk Activities***

The Products are not fault-tolerant and are not designed, manufactured or intended for use or resale as on-line control software in hazardous environments requiring fail-safe performance, such as in the operation of nuclear facilities, aircraft navigation or communication systems, air traffic control, direct life support machines, or weapons systems, in which the failure of the Products could lead directly to death, personal injury, or severe physical or environmental damage ("High Risk Activities"). Zebra and its suppliers specifically disclaim any express or implied warranty of fitness for High Risk Activities, and if you elect to use the Products in any High Risk Activities, you agree to indemnify, defend, and hold Zebra harmless from and against any and all costs, damages, and losses related to that use.

### ***U.S. Government***

If you are acquiring the Products on behalf of any unit or agency of the U.S. Government, the following shall apply. Use, duplication, or disclosure of the Products is subject to the restrictions set forth in subparagraphs (c) (1) and (2) of the Commercial Computer Software - Restricted Rights clause at FAR 52.227-19 (JUNE 1987), if applicable, unless being provided to the Department of Defense. If being provided to the Department of Defense, use, duplication, or disclosure of the Products is subject to the restricted rights set forth in subparagraph (c) (1) (ii) of the Rights in Technical Data and Computer Software clause at DFARS 252.227-7013 (OCT 1988), if applicable. Products may or may not include a Restricted Rights notice, or other notice referring specifically to the terms and conditions of this Agreement. The terms and conditions of this Agreement shall each continue to apply, but only to the extent that such terms and conditions are not inconsistent with the rights provided to you under the aforementioned provisions of the FAR and DFARS, as applicable to the particular procuring agency and procurement transaction.



## **Assignment**

Except as otherwise provided in this section, neither party may assign this Agreement, or any of its rights or obligations under this Agreement, without the prior written approval of the other party, which will not be unreasonably withheld. Any attempted assignment, delegation, or transfer without the necessary approval will be void. Notwithstanding the foregoing, for any Zebra acquisition, merger, consolidation, reorganization, or similar transaction, or any spin-off, divestiture, or other separation of a Zebra business, Zebra may, without the prior written consent of the other party: (i) assign its rights and obligations under this Agreement, in whole or in part, or (ii) split and assign its rights and obligations under this Agreement so as to retain the benefits of this Agreement for both Zebra and the assignee entity(ies) (and their respective Affiliates) following the split.

## ***Governing Law***

This Agreement shall be governed by the laws of the United States of America to the extent that they apply and otherwise by the laws of the State of New York without regard to its conflict of laws provisions or by the internal substantive laws of the country to which the Products is shipped if end-user customer is a sovereign governmental entity. The terms of the U.N. Convention on Contracts for the International Sale of Goods do not apply. In the event that the Uniform Computer Information Transaction Act, any version of this Act, or a substantially similar law (collectively "UCITA") becomes applicable to a Party's performance under this Agreement, UCITA does not govern any aspect of this End User License Agreement or any license granted under this End-User License Agreement, or any of the parties' rights or obligations under this End User License Agreement. The governing law will be that in effect prior to the applicability of UCITA.

## ***Compliance with Laws***

Licensee will comply with all applicable laws and regulations, including export laws and regulations of the United States. Licensee will not, without the prior authorization of Zebra and the appropriate governmental authority of the United States, in any form export or re-export, sell or resell, ship or reship, or divert, through direct or indirect means, any item or technical data or direct or indirect products sold or otherwise furnished to any person within any territory for which the United States Government or any of its agencies at the time of the action, requires an export license or other governmental approval. Violation of this provision will be a material breach of this Agreement, permitting immediate termination by Zebra.

### *Third Party Software*

The Products may contain one or more items of Third-Party Software. The terms of this Agreement govern your use of any Third-Party Software UNLESS A SEPARATE THIRD-PARTY SOFTWARE LICENSE IS INCLUDED, IN WHICH CASE YOUR USE OF THE THIRD-PARTY SOFTWARE WILL THEN BE GOVERNED BY THE SEPARATE THIRD-PARTY LICENSE.

### *Open Source Software*

The Products may contain one or more items of Open Source Software. Open Source Software is software covered by a publicly available license governed solely under Copyright law, whereas the complete terms and obligations of such license attach to a licensee solely through the act of copying, using and/or distribution of the licensed software, such obligations often include one or more of attribution obligations, distribution obligations, copyright obligations, and intellectual property encumbrances. The use of any Open Source Software is subject to the terms and conditions of this Agreement as well as the terms and conditions of the corresponding license of each Open Source Software package. If there is a conflict between the terms and conditions of this Agreement and the terms and conditions of the Open Source Software license, the applicable Open Source Software license will take precedence. Copies of the licenses for the included Open Source Software, if any, as well as their attributions, acknowledgements, and software information details, are provided in the electronic copy of this Agreement, which is available in the Legal Notices or README file associated with the Product. Zebra is required to reproduce the software licenses, acknowledgments and copyright notices as provided by the authors and owners, thus, all such information is provided in its native language form, without modification or translation. Depending on the license terms of the specific Open Source Software, source code may not be provided. Please reference and review the entire Open Source Software information to identify which Open Source Software packages have source code provided or available. For instructions on how to obtain a copy of any source code made publicly available by Zebra related to Open Source Software distributed by Zebra, you may send your request (including the Zebra Product name and version, along with the Open Source Software specifics) in writing to: Zebra Technologies Corporation, Open Source Software Director, Legal Department, 3 Overlook Point, Lincolnshire, IL 60069 USA.

©2016 ZIH Corp and/or its affiliates. All rights reserved. Zebra and the stylized Zebra head are trademarks of ZIH Corp., registered in many jurisdictions worldwide. All other trademarks are the property of their respective owners.

## 8 AP-7522 Access Point China ROHS Compliance

部件名称 (Parts)	有害物质 					
	铅 (Pb)	汞 (Hg)	镉 (Cd)	六价铬 (Cr(VI))	多溴联 苯 (PBB)	多溴二苯 醚 (PBDE)
金属部件 (Metal Parts)	X	○	○	○	○	○
电路模块 (Circuit Modules)	X	○	○	○	○	○
电缆及电缆组件 (Cables and Cable Assemblies)	X	○	○	○	○	○
塑料和聚合物部件 (Plastic and Polymeric Parts)	○	○	○	○	○	○
光学和光学组件 (Optics and Optical Components)	○	○	○	○	○	○
电池 (Batteries)	○	○	○	○	○	○

本表格依据 SJ/T 11364 的规定编制。

○: 表示该有害物质在该部件所有均质材料中的含量均在 GB/T 26572 规定的限量要求以下。

X: 表示该有害物质至少在该部件的某一均质材料中的含量超出GB/T 26572 规定的限量要求。  
(企业可在此处, 根据实际情况对上表中打“×”的技术原因进行进一步说明。)

This table was created to comply with China RoHS requirements for AP-7522 and AP-7522I Access Points.



